

CITATION CJ3



Specification & Description

July 2008, Revision F
Units 525B-0294 to TBD

SPECIFICATION AND DESCRIPTION

UNITS 525B-0294 TO TBD

JULY 2008

REVISION F

**Citation Marketing
Cessna Aircraft Company
P.O. Box 7706
Wichita, Kansas 67277-7706**

July 2008, Revision F

INTRODUCTION

Advanced Fully Integrated Avionics for the Citation CJ3

Combining the latest technology sensors and displays in an integrated package that is both smaller and lighter than traditional avionics, the Collins Pro Line 21 suite for the CJ3 is a true breakthrough in flight deck efficiency and pilot workload reduction. It integrates pilot information into intuitive, easy to interpret new formats with safety enhancing reversion capability.

At the heart of all the advancements found in the Pro Line 21 system are the Pro Line 21 radios and the Collins File Server Unit (FSU). The FSU serves as a portal for software and database uploads, allowing new capabilities to be added as airspace requirements and technology evolve. The net result is a flexible, cost-effective, reusable architecture with inherent growth capability and true software mobility. Maximizing the system's high-performance, partitioned processing capabilities, Ethernet interfaces and active matrix liquid crystal display (AMLCD) flight displays, the FSU integrates with this new technology to provide enhancements such as Integrated Flight Information System (IFIS) with functionalities including electronic charting, graphical weather and enhanced mapping for the flight deck.

All primary flight, navigation, engine and sensor data is graphically presented on the system's three large liquid crystal displays for easy scanning and integration. Standard pilot and copilot primary flight displays (PFDs) are teamed with an enhanced central multi-function display (MFD), a Collins FMS-3000 Flight Management System and dual radio-tuning units (RTUs) to streamline and automate input functions. This helps to ensure more eyes-up time at the controls, giving pilots a better overall view of their real-time flight situation.

There's never been a system this capable--or futuristic--in this category of aircraft. But then, offering exceptional value is what Cessna and the Citation CJ3 are all about.

This Specification and Description is published for the purpose of providing general information for the evaluation of the design, performance, and equipment of the Cessna Citation CJ3, Units 525B-0294 to TBD. This document supersedes all previous Specification and Description documents and describes only the Cessna Citation CJ3 Model 525B, its powerplants and equipment.

Due to the time span between the date of this Specification and Description and the scheduled delivery date of the Aircraft, Cessna reserves the right to revise the Specification whenever occasioned by product improvements, government regulations or other good cause as long as such revisions do not result in a material reduction in performance.

In the event of any conflict or discrepancy between this document and the terms and conditions of the purchase agreement to which it is incorporated, the terms and conditions of the purchase agreement govern.

For additional information contact:

Citation Marketing
Cessna Aircraft Company
P.O. Box 7706
Wichita, Kansas 67277-7706

Telephone: 316-517-6449
Telefax: 316-517-6640

WARNING: This product contains Halon 1211, Halon 1301, and also R-134A. Furthermore, the product was manufactured with CFC-12 and 1-1-1 Trichloroethane, substances which harm public health and environment by destroying ozone in the upper atmosphere.

TABLE OF CONTENTS

Cessna Citation CJ3 Specification and Description

Section	Page
1. General Description	3
1.1 Certification	3
1.2 Approximate Dimensions	3
1.3 Design Weights and Capacities	6
2. Performance	6
3. Structural Design Criteria	7
4. Fuselage	7
5. Wing	7
6. Empennage	7
7. Landing Gear	8
8. Powerplants	8
9. Systems	8
9.1 Flight Controls	8
9.2 Fuel System	8
9.3 Hydraulic System	9
9.4 Electrical System	9
9.5 Pressurization and Environmental System	9
9.6 Oxygen System	9
9.7 Ice and Rain Protection	9
10. Flight Compartment, Instrumentation and Avionics	10
10.1 General	10
10.2 Instrument and Control Panels	10
10.3 Avionics	12
10.4 Miscellaneous Cockpit Equipment	15
11. Interior	16
11.1 General	16
11.2 Standard Interior Configuration	17
11.3 Baggage	17
12. Exterior	18
13. Additional Equipment	18
14. Emergency Equipment	18
15. Documentation and Technical Publications	18
16. Computerized Maintenance Record Service (CESCOM)	19
17. Limited Warranties	19
17.1 Cessna Citation CJ3 Limited Warranty	19
17.2 Williams FJ44-3A Limited Engine Warranty	20
18. Citation CJ3 Crew Training Agreement	22
FIGURE I — CITATION CJ3 EXTERIOR DIMENSIONS	4
FIGURE II — CITATION CJ3 INTERIOR DIMENSIONS	5
FIGURE III — CITATION CJ3 INSTRUMENT PANEL AND PEDESTAL LAYOUT	11
FIGURE IV — CITATION CJ3 STANDARD FLOORPLAN	16

July 2008, Revision F

MANUFACTURER _____ CESSNA AIRCRAFT COMPANY

MODEL _____ 525B

1. GENERAL DESCRIPTION

The Cessna Citation CJ3 is a low-wing aircraft with retractable tricycle landing gear and a "T" tail. A pressurized cabin accommodates a crew of two and up to eight passengers (six is standard). Two Williams International Co., LLC (Williams) FJ44-3A FADEC controlled turbofan engines are pylon-mounted on the rear fuselage. Fuel stored in the wings offers generous range for missions typical of this class aircraft. Space for baggage is provided in the nose and tailcone with additional storage space available in the cabin. The CJ3 also incorporates an all new LED lighting suite allowing for reduced power consumption, reduced weight and a replacement time of 8000 hours.

Multiple structural load paths and system redundancies have been built into the aluminum airframe. Metal bonding techniques have been used in many areas for added strength and reduced weight. Certain parts with non-critical loads such as the nose radome and fairings are made of composite materials to save weight. The airframe design incorporates anti-corrosion applications and lightning protection.

1.2 Approximate Dimensions

Overall Height	15 ft 2 in (4.62 m)
Overall Length	50 ft 2 in (15.29 m)
Overall Width	53 ft 4 in (16.26 m)

Wing

Span (does not include tip lights)	52 ft 11 in (16.13 m)
Area	294.1 ft ² (27.32 m ²)
Sweepback (at 31% chord)	0 degrees

Horizontal Tail

Span (overall)	20 ft 10 in (6.35 m)
Area	70.7 ft ² (6.57 m ²)
Sweepback (at 25% chord)	20 degrees

Vertical Tail

Height	7 ft 5 in (2.26 m)
Area	56.3 ft ² (5.23 m ²)
Sweepback (at 25% chord)	49 degrees

Cabin Interior

Height (maximum over aisle)	57 in (1.45 m)
Width (trim to trim)	58 in (1.47 m)
Length (forward pressure bulkhead to aft pressure bulkhead)	20 ft 7 in (6.27 m)

Landing Gear

Tread (main to main)	16 ft 0 in (4.88 m)
Wheelbase (nose to main)	20 ft 0 in (6.10 m)

Cessna offers a third-party training package for pilots and mechanics, and various manufacturers' warranties as described in this Specification and Description book. Cessna's worldwide network of company-owned and authorized service centers provides a complete source for all servicing needs.

1.1 Certification

The Model 525B is certified to the requirements of U.S. 14 CFR Part 23, Commuter Category, including day, night, VFR, IFR, and flight into known icing conditions. It is also certified for single pilot operations for U.S. registered aircraft. The Citation CJ3 is compliant with all RVSM certification requirements. (Note: specific approval is required for operation within RVSM airspace; Cessna offers a no charge service to assist with this process.)

The Purchaser is responsible for obtaining aircraft operating approval from the relevant civil aviation authority. International certification requirements may include modifications and/or additional equipment; such costs are the responsibility of the Purchaser.

1. GENERAL DESCRIPTION (Continued)

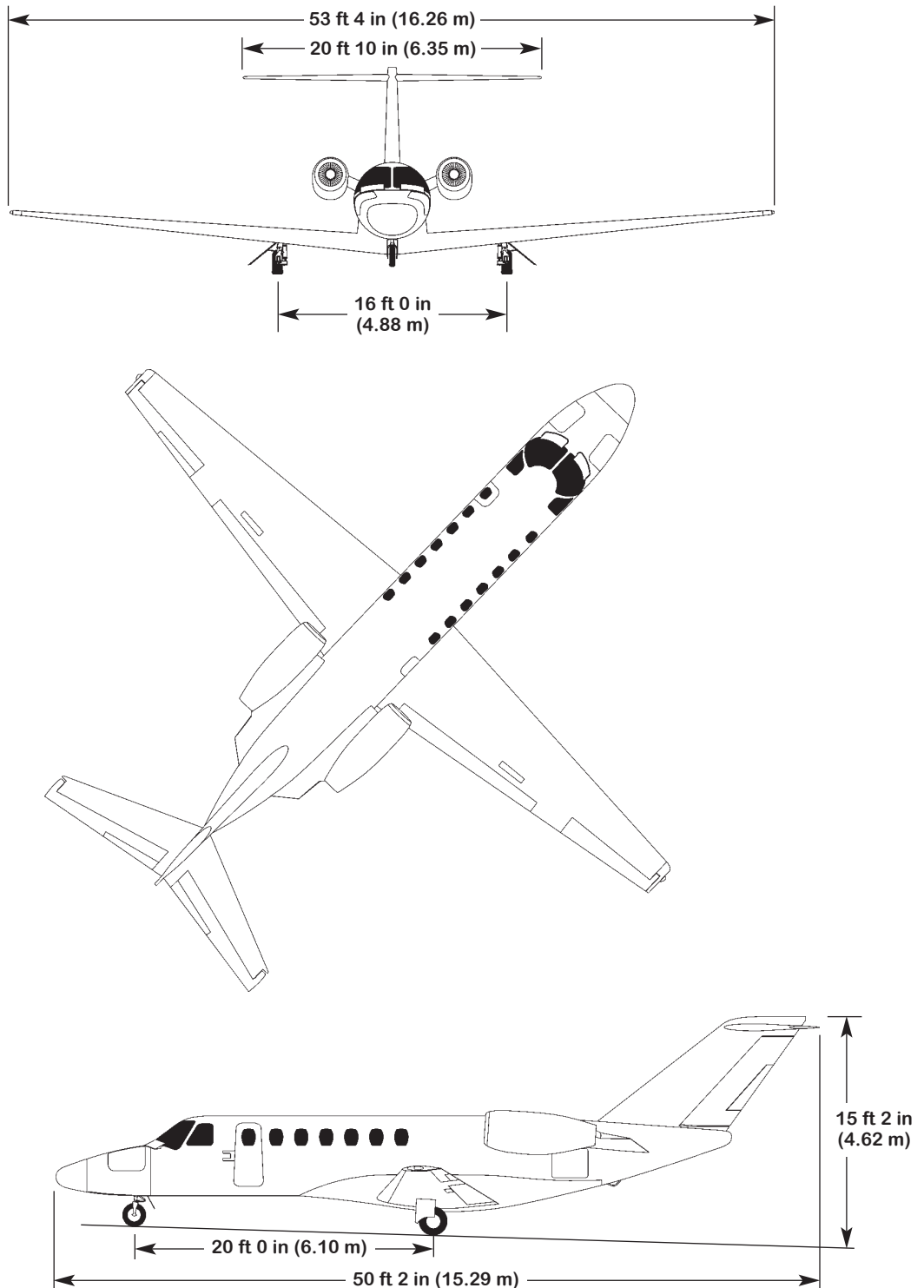

FIGURE I — CITATION CJ3 EXTERIOR DIMENSIONS

July 2008, Revision F

1. GENERAL DESCRIPTION (Continued)

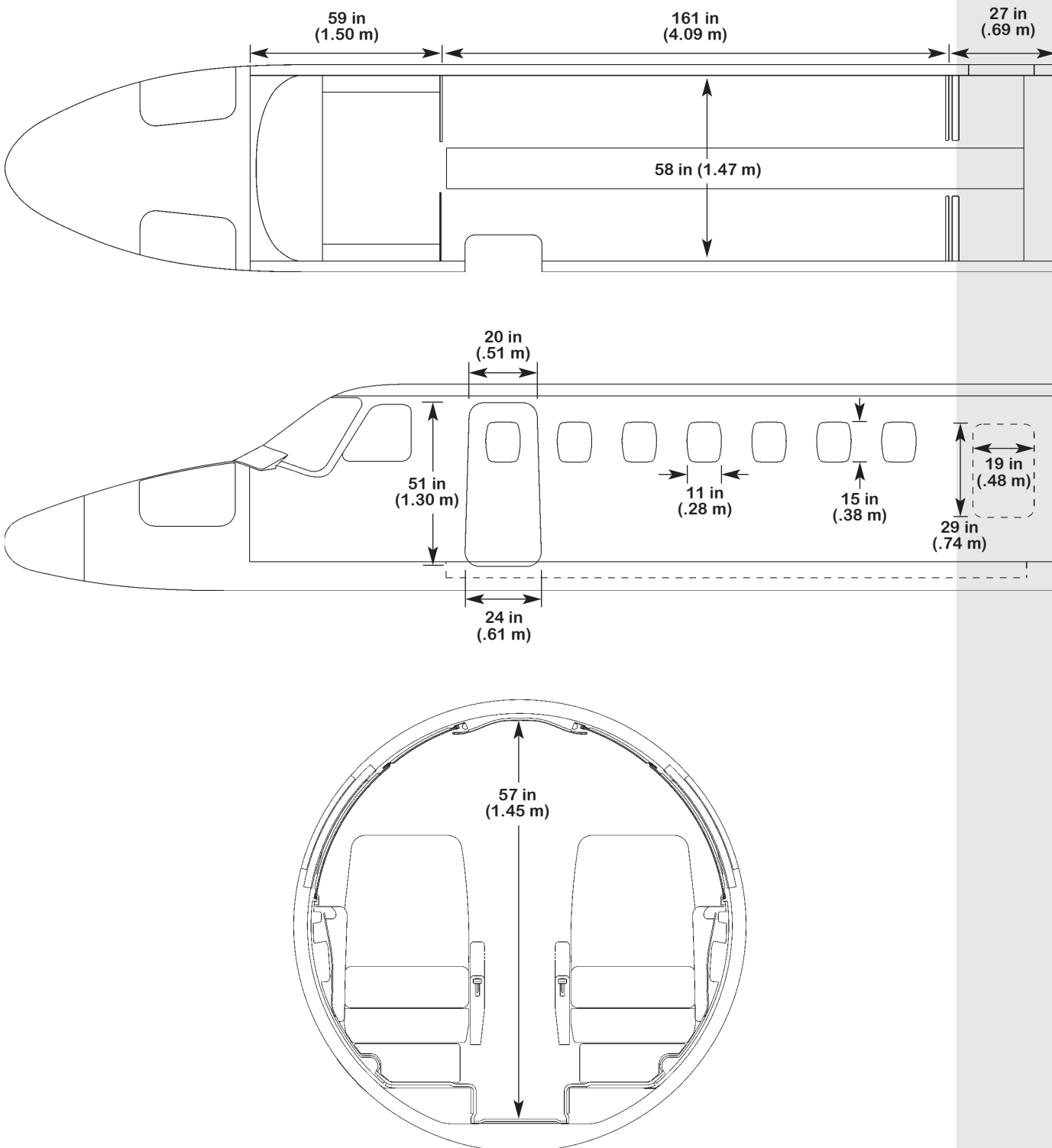

FIGURE II — CITATION CJ3 INTERIOR DIMENSIONS

1. GENERAL DESCRIPTION (Continued)

1.3 Design Weights and Capacities

Maximum Ramp Weight	14,070 lb (6,382 kg)
Maximum Take Off Weight	13,870 lb (6,291 kg)
Maximum Landing Weight	12,750 lb (5,783 kg)
Maximum Zero Fuel Weight	10,510 lb (4,767 kg)
Standard Empty Weight *	8,185 lb (3,713 kg)
Useful Load	5,885 lb (2,669 kg)
Fuel Capacity (useable) at 6.70 lb/gal	4,710 lb (2,136 kg)

* Standard empty weight includes unusable fuel, full oil, standard interior, and standard avionics.

2. PERFORMANCE

All performance data is based on a standard aircraft configuration, operating in International Standard Atmosphere conditions with zero wind. Takeoff and landing field lengths are based on a level, hard surface, dry runway.

Actual performance will vary with individual airplanes and other factors such as environmental conditions, aircraft configuration, and operational/ATC procedures.

Takeoff Runway Length (Maximum Takeoff Weight, Sea Level, ISA, Balanced Field Length per 14 CFR Part 25, 15° Flaps)	3,180 ft (969 m)
Climb Performance (Maximum Takeoff Weight, from Sea Level, ISA)	27 min to 45,000 ft (13,716 m)
Maximum Altitude	45,000 ft (13,716 m)
Maximum Cruise Speed (± 3%) (Mid-Cruise Weight, 33,000 ft (10,058 m), ISA)	417 KTAS (772 km/hr or 480 mph)
NBAA IFR Range (100 nm alternate) (± 4%) (Maximum Takeoff Weight, Full Fuel, Optimal Climb and Descent, Maximum Cruise Thrust at 45,000 feet)	1,875 nm (3,473 km or 2,158 mi)
Landing Runway Length (Maximum Landing Weight, Sea Level, ISA, per 14 CFR Part 25)	2,770 ft (844 m)
Certificated Noise Levels	
Takeoff	74.0 EPNdB
Sideline	88.8 EPNdB
Approach	88.6 EPNdB

July 2008, Revision F

3. STRUCTURAL DESIGN CRITERIA

The Citation CJ3 airframe is conventional in design, incorporating aluminum alloys, steel and other materials as appropriate. Engineering principles using multiple load paths, low stress levels and small panel size are

incorporated in the primary structure. The structure supports a nominal maximum cabin pressure differential of 8.9 psi (.61 bar).

Limit Speeds

V_{MO} 8,000 ft (2,438 m) to 29,300 ft (8,931 m)	278 KIAS (515 km/hr, 320 mph)
M_{MO} 29,300 ft (8,392 m) and above	Mach 0.737 (indicated)

Flap Extension Speeds

V_{FE} 0° to 15° Extension	200 KIAS (370 km/hr, 230 mph)
V_{FE} 15° to 35° Extension	160 KIAS (296 km/hr, 184 mph)

Landing Gear Operating and Extended Speeds

V_{LO} (retracting)	200 KIAS (370 km/hr, 230 mph)
V_{LO} (extending)	250 KIAS (463 km/hr, 288 mph)
V_{LE}	250 KIAS (463 km/hr, 288 mph)

4. FUSELAGE

The fuselage has a constant circular cross section and is attached to the wing without any cutouts for the spar. A dropped aisle from just behind the cockpit through the lavatory makes moving about the cabin easier. The keyed cabin door is located on the forward left-hand side of the fuselage. It has 12 locking pins and two pressure seals and is hinged forward with a folding two-step entry stair mounted just inside the entrance. A plug-type emergency exit is located on the aft right-hand side of the cabin. The windshields are designed to meet bird resistance requirements of 14 CFR Part 25. Framing structures surround the main door opening, emergency exit, and windshield providing structural continuity.

The nose section includes a generous baggage compartment from which the avionics bay, oxygen bottle, and windshield alcohol supply are accessible. Behind the composite radome is the high-resolution weather radar antenna and processor.

The tailcone houses the major components of the hydraulic, environmental, electrical distribution, flight controls, and engine fire extinguishing systems. A baggage compartment is also located in the tailcone. External access to both the equipment and the baggage area is provided through a baggage door on the lower left-hand side of the tailcone and removable exterior panels.

5. WING

The straight wing design of the CJ3 incorporates a natural laminar flow airfoil. The wing structure is a three spar design with a shallow drop in the center section to permit attachment of the fuselage without interruption of the cabin cross-section.

The wing leading edges are anti-iced using engine bleed air. Composite fairings blend the wing and fuselage for minimum drag. The landing lights consist of industry proven OSRAM LED technology and are integrated with a Pulselight system which are mounted below the fuselage in the fairing. The wing tips include LED position and anti-collision lights and static wicks.

Integral fuel tanks are located in each wing. Control surfaces on the wing include outboard ailerons, wide span flaps with a lift-dump feature, and upper and lower surface speed brakes. The left-hand aileron incorporates a trim tab.

6. EMPENNAGE

The empennage section is a T-tail design with a one-piece horizontal stabilizer. The horizontal stabilizer's leading edge is equipped with pneumatic de-ice boots. The rudder

includes a bias system and both the rudder and the elevators have pilot-controlled trim tabs. A tail logo light is standard with a red LED ground recognition light mounted on the top.

7. LANDING GEAR

The main and nose landing gear each use a single wheel assembly. The landing gear retraction system is electrically controlled and hydraulically actuated. Each main gear is a trailing link type and retracts inboard into the wing. The nose gear retracts forward into the fuselage and, when retracted, is enclosed by doors. The nose gear has a chine tire for water and slush deflection. Emergency landing gear extension is accomplished by manual release of the uplocks for free fall followed by use of the pneumatic blow-down system.

Multiple disc, digital anti-skid brakes are installed on the main gear wheels. An independent hydraulic system provides normal power braking with a pneumatic system for back-up.

The landing gear may be extended at speeds up to 250 KIAS. A warning horn will sound with the gear retracted if airspeed is below 130 KIAS and either throttle is retarded below approximately 85% N_2 . The nose gear is mechanically steered by the rudder pedals to 20 degrees either side of center. For ground handling maximum deflection of the nosewheel is 95 degrees either side of center.

8. POWERPLANTS

Two Williams FJ44-3A turbofan engines are installed, one on each side of the rear fuselage in easily accessible nacelles. This engine is a medium bypass, twin-spool design with 5 compression stages and 3 turbine stages and produces 2,820 pounds (12.54 kN) of takeoff thrust at sea level, static conditions, flat rated up to 79°F (26°C).

Dual channel Full Authority Digital Engine Controls (FADECs) provide automation and efficiency in engine management. Detents in the throttle quadrant for takeoff (TO), maximum continuous (MCT), and high speed cruise (CRU) give pilots the optimal power settings for each phase of flight based on ambient conditions. The system also provides time-limited dispatch (TLD), diagnostics,

and engine synchronization. Electrical power for the FADECs comes from engine driven permanent magnet alternators (PMAs) rectified to DC. There are two PMAs mounted to each engine. In the event that both PMAs fail on one engine, the FADEC on that side will draw from main DC power.

The FJ44-3A engine incorporates a modular design and multiple borescope ports for easier maintenance and inspections. Engine overhaul is required at 4,000 hour intervals. A continuous loop fire detection system monitors the nacelle area to detect and warn if a fire occurs. A fire extinguishing system is provided.

9. SYSTEMS

9.1 Flight Controls

Dual flight controls are provided consisting of control wheel columns, adjustable rudder pedals, brakes and mechanical nose wheel steering. Pushrod, bellcrank, sector, and cable systems are used to actuate the rudder, elevators, and ailerons. Corrosion resistant stainless steel cables are used in all primary and secondary systems.

Trim wheels installed on the pedestal control mechanical trim tabs for the ailerons, elevators, and rudder. The elevator trim also has an electric motor controlled by switches on each pilots' control wheel. A yaw damper system in the tail works with the autopilot to augment stability at high altitudes, however, it's not required for dispatch. A bias system is incorporated into the rudder for improved runway performance and automatic control enhancement during engine out conditions. An integral control lock below the pilot's panel holds the rudder, elevators, ailerons and throttles during storage.

Wide span flaps are controlled by a handle on the pedestal with detents at 15, 35, and 55 degrees. Any intermediate position from zero to 35 degrees may be selected in flight. The 55 degree position, or ground flaps is for lift dump and increased drag only during landing and will automatically cause the speed brakes to deploy. Speed brakes extend above and below each wing and may be extended in flight at any speed. However, they will automatically retract anytime either engine's N_2 speed is 85% or greater. The flaps and the speed brakes are electrically controlled and hydraulically actuated.

9.2 Fuel System

There are two integral fuel tanks, one per wing. System operation is fully automatic throughout the normal flight profile with each engine receiving fuel from its respective wing tank. Fuel is heated through an oil heat exchanger and anti-ice additive is not required. Refueling is accomplished through over wing filler ports.

July 2008, Revision F

9. SYSTEMS (Continued)

9.3 Hydraulic System

The hydraulic system is an open-center design providing 1,500 psi (103.4 bar) on demand to operate the landing gear, speed brakes, and flaps. Two engine-driven pumps, one located on each engine, supply hydraulic pressure. Either pump can supply enough pressure and flow to operate the system. An independent hydraulic system, driven by an electric motor, operates the wheel brakes and anti-skid system, and charges the emergency accumulator.

9.4 Electrical System

The CJ3 electrical power generation and distribution system features traditional parallel bus architecture designed to provide 600 amperes at 29 volts DC from two engine driven 300 ampere starter/generators. One 44 ampere-hour nickel cadmium battery is used for initial engine starts and serves as a limited backup to the generators.

Each generator is connected to a remote digital generator control unit (GCU) in the tailcone. The two GCUs are connected to each other to allow proportionate load sharing. If one generator becomes disabled in flight, the vapor cycle air conditioning system, if in use, and the entire suite, will automatically load shed to prevent overloading the remaining generator. All other essential electrical systems are supplied by the remaining generator through the respective main and crossfeed busses.

All system controls are located on the left-hand switch panel with gauges for system voltage and each generator's amperage. Left and right circuit breaker panels are positioned on the cockpit sidewall within easy reach of each pilot. A junction box is accessible through the aft baggage compartment. The battery, with quick disconnect, is accessible through the aft wall of the baggage compartment. An external power receptacle is provided below the left engine pylon.

A 500 watt inverter supplies 110 volt AC power to three outlets: one in the copilot's sidewall and two in the cabin next to each table.

9.5 Pressurization and Environmental System

Engine bleed air is tapped to pressurize the cabin. Cabin altitude and rate of change are automatically managed by a digital, auto-schedule controller. A nominal maximum differential pressure of 8.9 psi (.61 bar) permits a sea level cabin altitude up to 23,586 feet (7,189 m), increasing to 8,000 feet (2,438 m) at the maximum cruise altitude (45,000 feet, 13,716 m).

Engine bleed air is also used to heat the cabin and to defog the windows. A vapor cycle air conditioning system provides cooling and may be operated anytime in the air and on the ground when ground power is connected or when the right engine is running. In flight, the system automatically shuts down if one generator falls off line. A cockpit thermostat permits automatic temperature control and a five-position flow divider allows proportioning of the airflow.

9.6 Oxygen System

A 50 cubic foot (1.42 m³) oxygen bottle, located in the nose, is provided with a high pressure gauge and bottle-mounted pressure regulator. Quick-donning pressure demand masks with microphones are provided at each crew seat, while automatic dropout constant-flow oxygen masks are provided at each passenger seat and above the toilet. Oxygen flow to the cabin is controlled by a sequencing regulator valve for optimal passenger usage.

9.7 Ice and Rain Protection

Engine bleed air is used for anti-ice protection of the engine inlets, pylon inlet ducts, wings and windshields. The pilot's windshield also utilizes a back-up alcohol anti-ice system. The horizontal stabilizer leading edges are fitted with pneumatic de-ice boots, inflated by engine bleed air (23 psi service air system). A timer manages the inflation cycle. The pitot tubes, static ports, and the AOA sensor are electrically anti-iced. Two windshield ice detection lights are mounted on the glareshield and a wing inspection light is positioned on the left side of the fuselage to assist in the detection of ice buildup during night flights.

Windshield rain removal is accomplished with engine bleed air during normal operations and by mechanically actuated rain doors to provide deflected airflow in heavy rain.

10. FLIGHT COMPARTMENT, INSTRUMENTATION AND AVIONICS

10.1 General

Two complete crew stations are provided with dual controls including control columns, adjustable rudder pedals, and brakes. The crew seats are fully adjustable and include five-point restraint harnesses. The emergency oxygen system provides two diluter demand masks for the crew members.

LED light panels and blue-white background lighting illuminate all cockpit instruments and switches. Overhead map lights are also provided. The pitot-static system includes three heated pitot sources and six heated static sources. Independent sources are used to drive the pilot's and copilot's flight instruments.

10.2 Instrument and Control Panels

A. Installed on Left-Hand Panel (pilot):

- Master Warning / Master Caution Lights
- Flight Director Mode Select Panel
- Primary Flight Display
- Display Control Panel
- Avionics Dispatch Switch
- Cockpit Speaker Mute Switch
- TCAS II/Pulselights Interface Switch
- Windshield Bleed Controls
- Cockpit and Instrument Lighting Controls
- Landing / Recognition Light Control
- FADEC Switches and Indicators
- Digital Clock
- Angle of Attack Indicator
- Pilot's Digital Audio Control Panel
- DC Voltmeter (Selectable to Generators or Battery)
- Two Generator Load Ammeters
- Rotary Test Switch
- Electrical Power Control
- Avionics Power Control
- Fuel Transfer Control
- Engine Start and Ignition Control
- Anti-Ice / De-Ice Controls
- Pilot's AHRS Control
- Exterior Lights Control

B. Installed on Right-Hand Panel (copilot):

- Flight Director Mode Select Panel
- Master Warning / Master Caution Lights
- Display Control Panel
- Primary Flight Display
- Course Knob Panel
- Copilot's AHRS and Flight Deck Lighting Controls
- Flight Hour Meter
- Copilot's Digital Audio Control Panel
- Blanking Plate for Optional CVR
- Oxygen Pressure Indicator
- ELT Remote Switch

C. Installed on Center Panel:

- Electronic Standby Instrument System
- Multi-Function Display
- Radio Tuning Units (Dual)
- TAWS Switches
- Landing Gear Control and Indicators

D. Installed on Environmental Control Panel:

- Cabin Rate of Climb and Pressurization System Digital Controller
- Emergency Cabin Pressure Dump Control
- Cockpit Air Distribution Control
- Vapor Cycle Air Conditioning Control
- Air Source Selection Control
- Manual Pressure Control
- Fan / Defog Control
- Cabin Altitude and Differential Pressure Gauge
- Ground Idle Switch
- Cabin Temperature Controls

E. Installed on Pedestal:

- Engine Power Levers
- Flap Position Indicator
- Flap Control
- Speed Brake Control
- Engine Synchronizer Switch
- FMS Control Display Unit (CDU)
- Remote Course, Altitude, Heading Preselect Control
- Cursor Control Panel
- Autopilot Control Panel
- Elevator Trim Control and Indicator
- Aileron Trim Control and Indicator
- Rudder Trim Control and Indicator
- Maintenance Diagnostic System Download Port

F. Instrument / Warning Systems:

- Annunciator Panel Coupled to Master Warning / Master Caution System
- Engine Fire Warning System
- Battery Temperature Overheat System
- Windshield Air Overheat System
- Autopilot Off Warning
- Autopilot Trim Warning (on EFIS and Autopilot Controller)
- Overspeed Warning
- Comparator Warning (on EFIS)
- Altitude Deviation Warning
- Decision Height Warning

July 2008, Revision F

10. FLIGHT COMPARTMENT, INSTRUMENTATION AND AVIONICS (Continued)

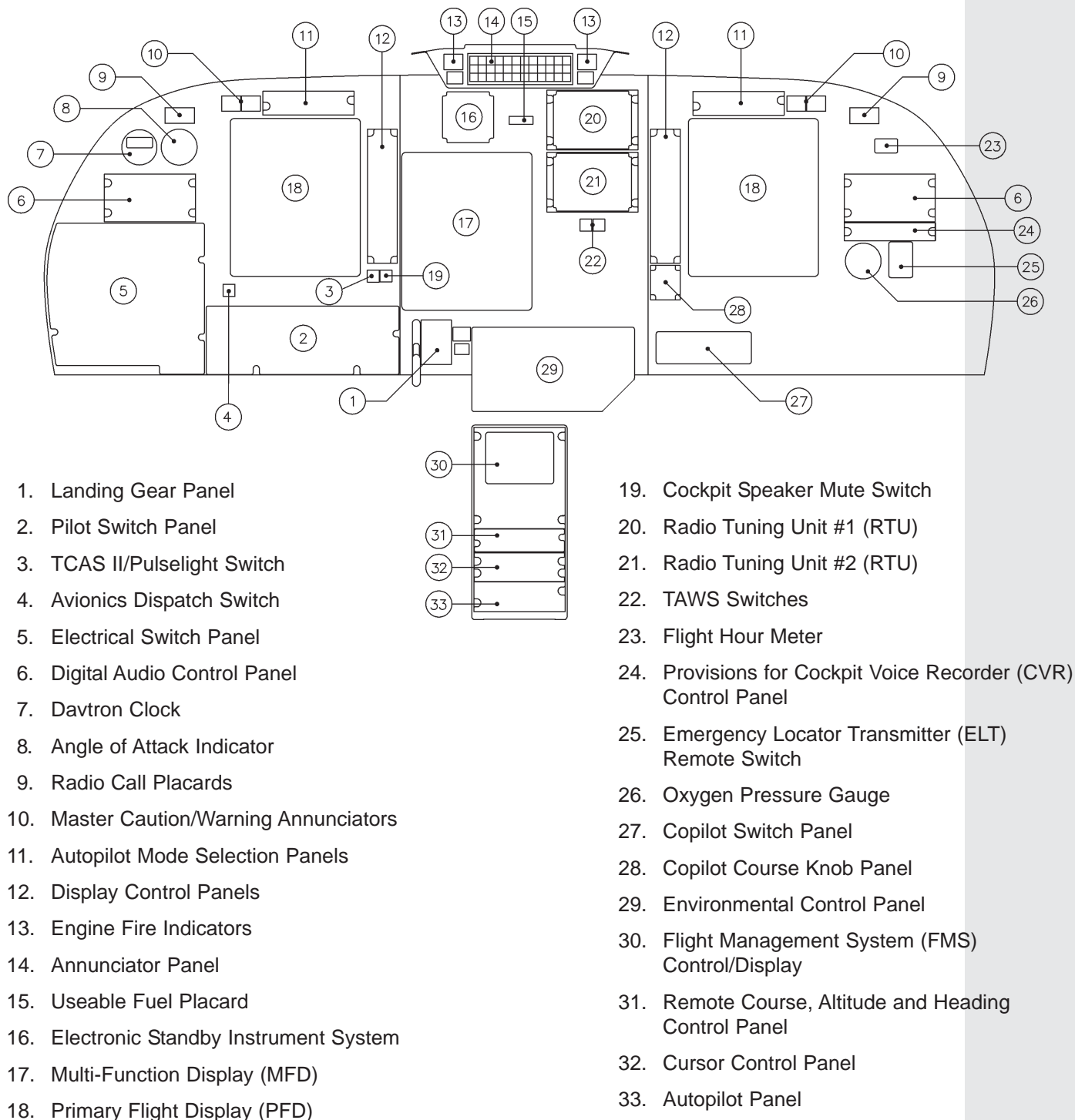

FIGURE III — CITATION CJ3 INSTRUMENT PANEL AND PEDESTAL LAYOUT

10. FLIGHT COMPARTMENT, INSTRUMENTATION AND AVIONICS (Continued)

10.3 Avionics

Described below is the Citation CJ3's standard avionics suite as referred to in the Limited Warranties (section 17).

A. Electronic Flight Displays

The Collins Pro Line 21 Avionics System is an integrated Flight Director/Autopilot and EFIS system utilizing three 8 x 10 inch (20 x 25 cm) color, Active Matrix Liquid Crystal Displays (AMLCD). The Primary Flight Displays (PFDs) are located on the pilot's and copilot's panel with an Enhanced Multi-Function Display (MFD) on the center panel. All displays are capable of providing compass, radar information, and engine parameters in reversion mode.

Dual Display Control Panels (DCP) and a Course Heading Panel (CHP), in conjunction with bezel-mounted switches, are the primary pilot interfaces with the PFDs. The DCPs provide dedicated controls for BARO setting, map range, and radar antenna tilt. The CHP provides the means to control selected course, selected heading, and pre-selected altitude. An additional course selector knob is located on the copilot's panel.

Each PFD displays an attitude sphere with respect to an aircraft symbol, and incorporates a single cue flight director command bar presentation. Dual digital air data computers supply information to the PFDs for presentation of altitude, airspeed, and vertical speed. Altimeter settings may be displayed in either inches or hectopascals and altitude in either feet or meters. Dual attitude heading reference systems supply attitude and magnetic or true heading information.

For aircraft heading, the PFDs display either a full compass rose, a partial compass arc, or a present position map format (PPOS). Situational awareness presentations (weather detection, TAWS and TCAS) may be overlaid on either the arc or PPOS map formats for both the PFDs and the MFD. The PFDs also display lateral navigation information in conjunction with the bearings and compass information. Temperatures (TAS, RAT, SAT and ISA deviation) are displayed at the bottom of each PFD. Various annunciations are presented for autopilot/flight director, display, vertical deviation, and distance.

The MFD has enhanced capabilities and is able to display a variety of graphical information. Engine parameters will be displayed at the top of the MFD, including N_1 ,

N_1 reference, thrust mode, ITT, ignition selected annunciation, N_2 , oil temp, oil pressure, fuel quantity, fuel flow and fuel temperature. Below the engine display is a window which may display extended FMS data or an integrated electronic checklist. The lower portion of the MFD displays navigation information in either a full compass rose, partial compass arc, PPOS map format or a planning map format. When charts are selected for display, the two lower sections of the MFD are merged to display charts only.

B. Flight Guidance System

The integrated Collins Pro Line 21 Flight Guidance System (FGS) consists of dual flight guidance computers and a single, three axis autopilot. Flight director modes consist of selected heading, lateral navigation capture and track, Go Around (GA) attitude, altitude hold, preselected altitude capture and track, vertical speed, IAS or Mach hold, and vertical navigation capture and track. In the absence of a vertical or lateral selected mode, the system will maintain pitch or roll attitude. Mode references can be synchronized to current aircraft parameters with a control wheel mounted SYNC switch. Flight director commands from either the pilot's or copilot's side may be coupled to the autopilot/yaw damper system, which consists of three electric servos in the primary flight control system along with an integral automatic or manual pitch trim system.

C. Attitude Heading Reference System (AHRS)

Dual Collins AHC-3000 solid-state Attitude/Heading Computers independently supply attitude and heading information to the EFIS and flight guidance system. Either AHC may be selected for display on each PFD via a cockpit switch. The heading reference may be slaved to a magnetic flux detector or may be operated in the free-gyro mode.

D. Air Data Computer (ADC)

Dual Collins ADC-3000 digital air data computers independently supply altitude, airspeed, vertical speed and temperature information to each pilot's PFD. Pressure altitude information is supplied to each Mode-S transponder, as well as to the FMS and FGS for vertical mode computations. In addition, a third ADC is dedicated to the Electronic Standby Instrument System.

July 2008, Revision F

10. FLIGHT COMPARTMENT, INSTRUMENTATION AND AVIONICS (Continued)

E. Integrated Flight Information System (IFIS)

The Collins IFIS-5000 is integrated with the FMS to provide a significant increase in situational awareness. The heart of the system is the line replaceable Collins FSU-5010 File Server Unit. The FSU contains the storage, memory, and processing power to display Enhanced Map Overlays on the MFD using high speed Ethernet connections. The cursor control device allows pilots to place overlays on the FMS navigation presentation such as worldwide political boundaries including state and national borders; geographical features such as lakes, rivers, and oceans; high and low enroute airways; and controlled, restricted, and prohibited airspace.

The IFIS Enhanced Map Overlay database is updated by subscription through Collins on a 28 day cycle and must be uploaded from the customer's laptop through the data port on the aft side of the pedestal. Inherent flexibility in the Collins IFIS allows for future expansion and/or upgrades to options currently available such as Jeppesen Electronic Charts.

F. Cursor Control Panel (CCP)

The Collins CCP-3000 is a control panel used in conjunction with the IFIS. It includes three Quick Access Keys, which allow rapid selection of pilot defined, pre-stored MFD formats. Other knobs and buttons support electronic checklist functions and menu functions for Enhanced Map Overlays.

G. Integrated Electronic Checklist

Capability for display of pilot-defined electronic checklists is included on the MFD. Control of the checklists is through the integral Cursor Control Panel, installed in the pedestal. Windows compatible software is provided for customized generation of checklist text pages.

H. Flight Management System (FMS)

The single Collins FMS-3000 provides a multiple waypoint navigation solution blended from available GPS, VOR, and DME sources, suitable for enroute, terminal, and non-precision approach navigation. Both lateral and vertical modes may be displayed on the Flight Director and may be fully coupled to the autopilot. Updated software adds Localizer Performance with Vertical Guidance (LPV) approach capability. Airway flight planning, plain language identifiers and airport communication and navigation fre-

quency lookup features are included. Present position referenced geopolitical, airspace, and major water boundaries as well as airways may be overlaid on any of the FMS map formats. The FMS keyboard provides an alternate tuning method for controlling the radio sensors and transponders. The FMS database requires updates by subscription through Collins on a 28 day cycle and must be uploaded from the customer's laptop through the data port on the aft side of the pedestal.

I. Global Positioning System (GPS)

The single Collins WAAS enabled GPS-4000S is a 12-channel receiver providing satellite-based position data for use by the FMS.

J. Radio Tuning Units (RTUs)

Dual Collins Radio Tuning Units (RTU-4200 series) provide redundant interface for control of all radio sensors. The center-panel mounted RTUs provide logical tuning and management for each communication, navigation, DME, ADF (optional), and HF (optional) radio as well as all TCAS and transponder functions. The RTUs feature non-volatile memory to retain all current and up to 20 preset frequencies for each radio and transponder. An intuitive menu structure minimizes pilot workload. The RTUs are integrated with the FMS for automatic tuning of navigation frequencies enroute. Each radio unit is isolated to prevent interference in the event of a failure of one unit, while continuous fault monitoring records anomalies for ease of diagnosis and maintenance.

The upper RTU also serves as a standby electronic horizontal situation indicator (EHSI) and is automatically activated if main electrical power is lost. In that case, the aircraft's heading in full compass card format is displayed along with VOR, localizer, glideslope, and ADF (optional).

K. Terrestrial Navigation Receivers

Two Collins NAV-4500 Navigation Receivers provide integration of all ground-based navigation functions. Dual VOR, Localizer, Glideslope, and Marker Beacon receivers are standard. A single ADF system may be ordered as an option. Navigation information is displayed on both PFDs and the MFD. Tuning and management is accomplished through the RTUs or the FMS keyboard.

10. FLIGHT COMPARTMENT, INSTRUMENTATION AND AVIONICS (Continued)

L. Distance Measuring Equipment (DME)

The Collins DME-4000 provides the ability to monitor as many as three active DME stations simultaneously. This allows full time distance display of pilot-selected VHF nav aids, along with the enhancement of FMS position determination through the use of non-displayed DME channels. Tuning and management is accomplished through the RTUs or the FMS keyboard.

M. Radio Altimeter

The Collins ALT-4000 Radio Altimeter system provides height above the terrain from 2,500 feet (762 m) to touch-down. This information is integrated with functions in the EFIS, TCAS, and TAWS and is presented on the PFDs.

N. VHF Communication Transceivers

The dual Collins VHF-4000 Transceivers provide a minimum of 16 watts power output and digital receiver and exciter technology, which will provide growth capability to support future VHF data link modes of operation. They are compliant with European 8.33 kHz spacing requirements. Tuning and management is accomplished through the RTUs or the FMS keyboard.

O. Audio Control Panel

Dual Collins digital audio control panel amplifiers provide transmitter selection for microphone inputs and direct audio outputs from all receivers to either the speaker or headphones at each crew station. They feature independent crew sidetone adjustment.

P. Cockpit Speaker Mute Switch

A switch in the forward pedestal allows the crew to mute all audio and aural warnings to the cockpit overhead speakers including TCAS and TAWS. (Note: This system may not be approved by some international regulation authorities, in which case, it may be disabled.)

Q. Transponders

Dual Collins Mode S Diversity solid-state transponders include enhanced surveillance capability with preparatory ADS-B out transmission functionality. Altitude reporting information is supplied from the digital ADCs. Each transponder is remotely mounted and tuned through the CDUs.

R. Traffic Collision Avoidance System (TCAS II)

The Collins TCAS-4000 system improves situational awareness by tracking all Mode C or S aircraft within 35 nm. This system, which meets all ICAO ACAS II (Change 7) requirements, selects for display only those aircraft (up to 30) that pose the greatest collision threat. Traffic Alerts (TAs) and Resolution Advisories (RAs) are given aurally through the aircraft audio system and visually on the PFDs. When other TCAS II-equipped aircraft are encountered, complementary RA maneuvers are coordinated by each system. Includes a panel switch that allows the TCAS-4000 to automatically cycle on and off both LED landing lights simultaneously to improve own aircraft visibility in flight in the event of a Resolution Advisory (RA) or Traffic Alert (TA).

S. Terrain Awareness Warning System (TAWS)

The L-3 Communications LandMark 8000 TAWS system compares GPS and altimetry data against internal, worldwide databases of navigation, terrain, and obstacles to predict position and warn of potential conflict. It displays terrain contours using multiple color shades, graphical depictions of runways (>2,000 feet), and man-made obstacles. This Class B system provides five basic alert modes: Forward Looking Terrain Avoidance (FLTA), Premature Decent, Excessive Decent Rate, Negative Climb Rate, and Descending to 500 Feet (no excessive bank angle alert). Aural advisories are provided through the aircraft audio system and are visually displayed on the PFDs and the MFD. The three main databases are updated periodically by subscription through L-3 Avionics, using a data port in the avionics bay.

T. Avionics Dispatch Switch

Installs a switch in the instrument panel that allows the battery to power one VHF radio, one RTU, both audio panels, MFD, FSU, Database Loader and both FMS systems for up to a half hour prior to engine start.

U. Weather Avoidance Radar

The Collins WXR-800 is a stabilized, single-unit, solid state, X-band color radar system. The depiction can be overlaid on the arc or present-position map displays on either the PFDs or MFD and corresponds to the map/radar range selected. The radar has a 120 degree scan angle over a selectable range of from five to 300 nm.

July 2008, Revision F

10. FLIGHT COMPARTMENT, INSTRUMENTATION AND AVIONICS (Continued)

V. Broadcast Weather

XM WX Satellite Weather Data service provides constantly updated weather information displayed on the MFD. Products such as high resolution NEXRAD, graphical echo tops, and METARs may be manipulated using the cursor control panel. The aircraft's present position is shown on the graphical images. Upgraded software features the capability to have satellite imagery with NEXRAD overlays, see TFRs both in graphical and textual formats, view winds aloft, and view cloud-to-cloud lighting with strikes refreshed every five minutes. Data is processed through a Heads Up Technologies receiver and stored for recall on demand. A subscription through XM is required and is currently available only within the Continental U.S.

W. Electronic Standby Instrument System (ESIS)

The L-3 Communications GH-3000 ESIS features solid-state internal sensors for attitude cues and an independent, dedicated air data computer (remotely mounted) for airspeed and altitude information. Flight reference information is presented in an EFIS-matched format on a full-color AMLCD.

X. Emergency Locator Transmitter (ELT)

The Artex C406-N is a three frequency ELT that transmits on the emergency frequencies of 121.5 and 243.0 MHz and the satellite frequency of 406 MHz. It interfaces with the onboard FMS and is capable of transmitting the last known aircraft position on the satellite frequency if activated. (Interface feature disallowed by some certifying agencies.)

Y. Cockpit Voice Recorder Provisions Only

Provisions for installation of the optional L-3 Communications FA2100 CVR includes all wiring and mounting chassis, the impact switch, the cockpit mounted area microphone, and a blanking plate.

Z. Collins Maintenance Diagnostic Computer

The Collins Maintenance Diagnostic System has the ability to collect, store, and display diagnostic data, service, and fault messages for many Collins Pro Line 21 Line Replaceable Units (LRUs). The maintenance data can be accessed on the MFD when the aircraft is on the ground. The Collins Pro Line 21 system diagnostics provides a listing of current faults, advanced diagnostics information for each current fault, currently failed LRUs,

and fault history. The system can store fault history for up to 500 faults occurring during the previous 100 flights. The MDS also provides maintenance reports which may be downloaded in ASCII format to a USB storage device.

Additional data storage is provided by a Cessna Diagnostic Aircraft Recording System (AReS). AReS contains approximately 8Gb of removable, non-volatile memory encompassing thousands of aircraft parameters captured during the previous 25+ flight hours. The AReS system also interfaces with Collins Pro Line 21 systems.

Powerful software will enable the technician to analyze and replay flight conditions to troubleshoot squawks, including intermittent failures, directly through the MFD and CDU. The need to re-fly with special equipment to catch intermittent problems has been eliminated.

Systems monitored include:

- AOA
- Audio
- Bleed Air
- Deice Control and Monitor
- Electric Pitch Trim
- Environmental
- Flap Controls
- Fuel Control
- Fuel Quantity
- GCU
- Landing Gear Position
- Pressurization
- Speed Brakes
- Start Control

Purchaser agrees that Cessna has a perpetual license to use all information contained in the AReS system for maintenance and accident investigation. Purchaser expressly provides Cessna with licensed permission to download, use and/or read such information at any time upon request. Purchaser further agrees this perpetual license runs with and is automatically transferred with the title to the Aircraft and is binding on any and all subsequent purchasers of the Aircraft.

10.4 Miscellaneous Cockpit Equipment

- Magnetic Compass
- Eye Position Reference Indicator
- Glareshield
- Ventilation Air Outlets (2)
- Oxygen System Control
- Oxygen Masks (2)
- Parking Brake Control
- Rain Removal Door Control
- Control Lock
- Emergency Brake Control
- Emergency Gear Extension Control
- Reading Lights (2)
- Floodlight

11. INTERIOR

11.1 General

The Citation CJ3's cockpit is designed to provide the crew with the tools for the job in a comfortable working environment. Single pilot capabilities mean that all essential controls are within easy reach from the left seat. Each crew seat is fully adjustable and includes a five-point restraint system. Left and right hand reading lights, air outlets, side-wall map pockets, and dual cupholders are provided as well as a two-book chart case behind the copilot's seat.

The standard configuration in the Citation CJ3 features a six-place center club and a refreshment center across from the entry door. A storage cabinet with adjustable shelves faces the refreshment center, just behind the pilot's seat. A center flush-mounted coat rod is provided across from the left-hand belted flushing toilet in the aft cabin lavatory. Sliding divider doors provide privacy.

Each passenger seat is mounted on a pedestal with the ability to track forward, aft, and laterally. Each seat may be reclined up to 45 degrees depending on its position on the pedestal. (The aft cabin divider restricts seats #7 and #8--see diagram.) The two center seats (#5 and #6) are mounted on floor tracks for greater flexibility. Individual air outlets and reading lights are provided in the Passenger Service Units (PSU) above each passenger. Dropout, constant-flow oxygen masks are also installed in the PSU for emergency use. Two cupholders are built into the side ledge next to each seat. In the lower side-wall next to seats #5 and #6 are two 110 VAC outlets, one on each side. Also built into the sideledges in the center club are foldout executive tables with leather inserts.

A five inch dropped aisle, extending from the cockpit divider aft through the lavatory, provides a cabin height of 57 inches. The constant cross section of the cabin provides a continuous width of 58 inches. (Measurements represent distance between softgoods.) The cabin is approximately 15 feet 8 inches long measured from the cockpit divider to the aft pressure bulkhead and offers flexibility for a variety of interior arrangements.

Included are dropped aisle lighting and indirect overhead LED lights in the PSU with full dimming capability. Entrance and emergency exit lights are also provided in the passenger cabin. Fourteen elliptical windows offer exceptional natural lighting throughout the cabin. Three panes per window and bagged insulation in the walls contribute to a quiet, comfortable cabin environment even at high speeds. With the exception of the entrance door, each window has pleated manual window shades.

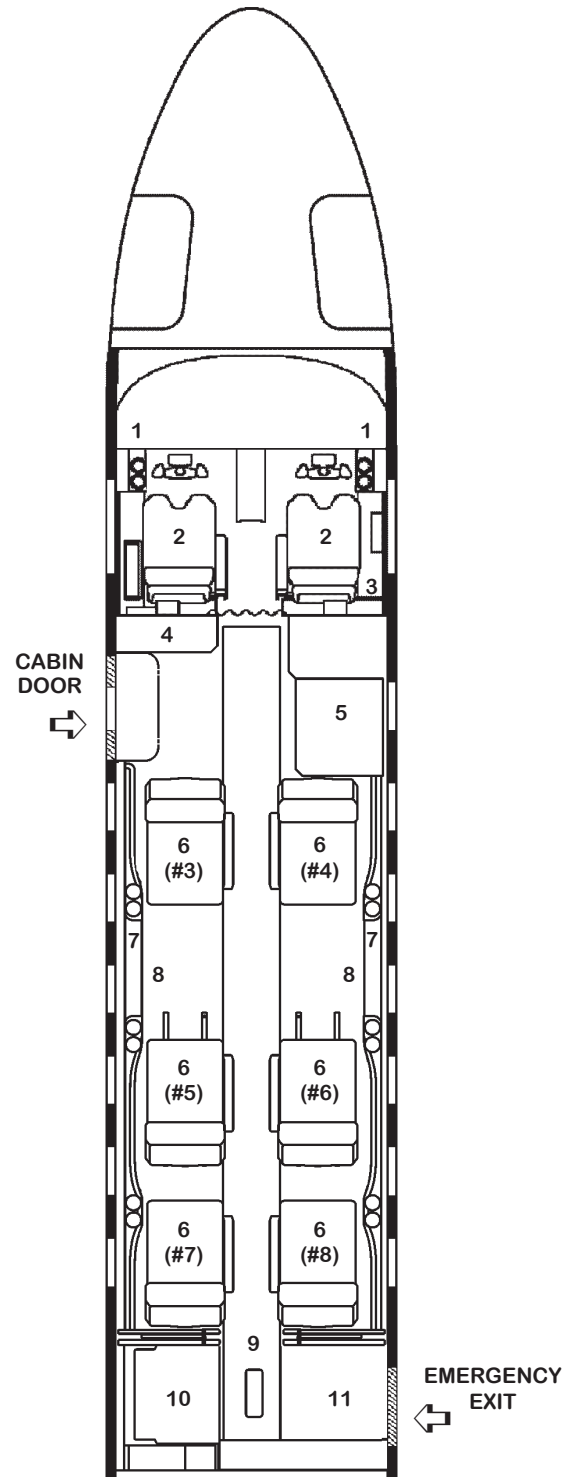

FIGURE IV — CITATION CJ3 STANDARD FLOORPLAN

July 2008, Revision F

11. INTERIOR (Continued)

An extensive selection of carpets, fabrics, leathers, and matte laminate cabinetry coverings, all burn-resistant, are included in the base price of the aircraft.

11.2 Standard Interior Configuration

The following items are standard in the Citation CJ3. Numbered items refer to the cabin diagram (Figure IV).

Cockpit

1. Dual cupholders for each crew seat
2. Two crew seats
 - Five-Point Restraint System
 - Stowable Inboard Armrest
 - Fwd & Aft Tracking Lever
 - Recline Adjustment Lever
 - Height Adjustment Lever
 - Adjustable Lumbar
 - Seat Back Pocket
 - Overwater Life Vest Located In Seat Base
3. RH two-book navigation chart case

Not Shown:

- Cockpit assist handle
- Flight deck pedestal guardrail
- Two monorail sunvisors
- Single 110 volt AC outlet in copilot sidewall
- Fire extinguisher

Cabin Area

4. LH forward storage/evaporator cabinet
5. RH forward refreshment center with:
 - One-piece, half-length cockpit curtain
 - Heated liquid container
 - Condiment storage drawers
 - Bottled water storage
 - Two dispensers for disposable cups
 - Beverage can storage
 - Catering drawer
 - Divided ice chest drawer with removable wine caddy, manual overboard drain and removable liner
 - Drip tray with manual overboard drain
 - Trash container
 - Work surface
 - Miscellaneous general storage
6. Six pedestal seats: two aft facing (#3 and #4), and four forward facing (#5, #6, #7, and #8) with:
 - Hidden headrest with slipcover pillows
 - Seat back pocket
 - Single retractable inboard armrest
 - Forward/aft and inboard/outboard tracking on pedestal
 - Floor tracking (seats #5 and #6 only)
 - 45 degree seat back recline (depending on position)
 - Seat restraint system including seat belt and retracting

- shoulder harness with inertial reel
 - Overwater life vest stored in seat base
7. LH/RH sideedge with dual cupholders at each pedestal seat location
 8. LH/RH executive tables with leather table top insert
 9. LH/RH aft cabin dividers with mirror treatment and sliding privacy doors
 10. LH aft, belted flushing toilet
 - Relief tube with overboard drain
 - Toilet tissue storage area
 11. RH aft carpet covered avionics lowboy cabinet, houses diagnostics and common PC boards

Not Shown:

- Two 110 volt AC outlets in lower sidewall at seats 5 and 6 with 5 amp maximum
- Passenger service units (PSU) containing an oxygen mask, air outlet, and reading light at each passenger seat location and in the aft lavatory area
- Manual pleated cabin window shades
- Indirect overhead LED lighting
- Dropped aisle LED lighting
- Matte laminate cabinetry finish
- Brushed aluminum hardware finish
- Foldable threshold carpet assembly
- Spare threshold carpet assembly
- Spare center aisle carpet assembly
- Aft center flush mounted coat rod
- Chime unit located in PSU
- Fasten seat belt/no smoking and emergency exit signs (Note: The no smoking sign remains illuminated at all times unless the optional smoking configuration is ordered.)
- Single insertable ashtray
- Fireblocking on all passenger seats
- Cabin fire extinguisher

11.3 Baggage

Two separate baggage areas provide a total volume of 65.0 cubic feet (1.84 m³) and a total weight capacity of 1,000 pounds (454 kg).

- An LED illuminated 15.0 cubic foot (.42 m³), 400 pound (182 kg) capacity lockable nose baggage compartment is externally accessible from either side of the aircraft.
- An LED illuminated 50.0 cubic foot (1.42 m³), 600 pound (272 kg) capacity baggage compartment is located in the tailcone and is externally accessible through a 20 x 26 inch (.51 x .66 m) lockable door on the left side beneath the engine pylon. Its shape accommodates skis up to 215 cm long.

12. EXTERIOR

Distinctive exterior styling is provided featuring polyurethane paint in a variety of colors.

13. ADDITIONAL EQUIPMENT

- Two Telex 850 Active Noise Reduction Headsets
- Pitot Covers
- Engine Inlet, Pylon Inlet, Exhaust, and Generator Inlet covers
- Static Discharge Wick Covers
- Tow Straps
- Tailcone Baggage Restraint Strap
- Emergency Escape Hatch Ground-Locking Pin
- Jack Pad Adapter (Nose)

14. EMERGENCY EQUIPMENT

- Fire Extinguisher in Cockpit and Cabin
- Individual Overwater Life Vests For All Seats
- Crew and Passenger Oxygen
- Exterior LED Emergency Exit Lighting
- Emergency Lighting Battery Pack

15. DOCUMENTATION AND TECHNICAL PUBLICATIONS

- U.S. Standard Airworthiness Certificate, FAA8100-2; Export Certificate of Airworthiness, FAA8130-4 or Special Airworthiness Certificate FAA8130-7 as appropriate
 - Airplane Flight Manual
 - Pilot's Operating Manual
 - Abbreviated Procedures Checklist
 - Weight and Balance Report
 - Weight and Balance program *
 - Planning and Performance booklet
 - Cabin Operating Manual
 - Passenger Information Cards
 - Log Books (Aircraft and Engines)
 - Service Bulletins and Service Letters - Engine **
 - Maintenance Manual - Airframe *
 - Maintenance Manual Chapter 5 - Time Limits and Maintenance Checks (hardcopy)
 - Maintenance Manual - Interior *
 - Maintenance Manual - Engine **
 - Illustrated Parts Catalog - Airframe *
 - Illustrated Parts Catalog - Interior *
 - Illustrated Parts Catalog - Engine **
 - Wiring Diagram Manual - Airframe *
 - Avionics Wiring Booklet *
 - Component Maintenance Manual *
 - Structural Repair Manual *
 - Nondestructive Testing Manual *
 - Illustrated Tool and Equipment Manual *
- Cessna will provide Service Bulletins, Service Letters and manual revisions for documents published by Cessna for five years beginning from the start date of airframe warranty.

* These documents are provided on CD-ROM or DVD.

** These publications / revisions are provided by the supplier following delivery.

July 2008, Revision F

16. COMPUTERIZED MAINTENANCE RECORD SERVICE (CESCOM) _____

Cessna will provide an online computerized maintenance record service for one full year from the date of delivery of a Citation CJ3 to the Purchaser.

This service will provide management and operations personnel with the reports necessary for the efficient control of maintenance activities. The service provides an accurate and simple method of keeping up with aircraft components, inspections, service bulletins and airworthiness directives while providing permanent aircraft records of maintenance performed.

Reports, available on demand, show the current status, upcoming scheduled maintenance activity and the history

of the aircraft maintenance activity in an online format, which is printable locally. Semi-annual reports concerning projected annual maintenance requirements, component removal history and fleet-wide component reliability are provided as part of the service.

Services are provided through a secure Internet Site requiring a computer with Internet connectivity. A local printer is required to print paper versions of the online reports and documentation. If receiving these services through the Internet is not feasible for an operation, a paper-based service delivered through the U.S. mail is available at an additional fee.

17. LIMITED WARRANTIES _____

The standard Citation CJ3 Aircraft Limited Warranty which covers the aircraft, other than Williams engines and associated engine accessories which are warranted separately is set forth below. Cessna specifically excludes vendor subscription services and the availability of vendor service providers for Optional and Customer Requested Equipment (CRQ) from Cessna's Limited Aircraft Warranty. Following Cessna's Limited Warranty, the engine and engine accessory warranty of Williams is set forth. Both warranties are incorporated by reference and made part of the Purchase Agreement. All warranties are administered by Cessna's Citation Warranty Department.

17.1 Cessna Citation CJ3 Limited Warranty (Limited Warranty)

Cessna Aircraft Company (Cessna) expressly warrants each new Citation CJ3 Aircraft (exclusive of engines and engine accessories supplied by Williams which are covered by their separate warranty), including factory-installed avionics and other factory-installed optional equipment to be free from defects in material and workmanship under normal use and service, except as set forth herein, to the first user for the following periods after delivery:

- (a) Five years or 5,000 operating hours, whichever occurs first, for Aircraft components manufactured by Cessna;
- (b) Five years or 5,000 operating hours, whichever occurs first, for Collins' standard avionics;
- (c) Two years for all other Standard Avionics;
- (d) One year for all Optional Avionics

(e) One year for Actuators, ACMs, Brakes, GCUs, Oleos, Starter Generators, Valves, Windshields, and Vendor items including engine accessories supplied by Cessna unless otherwise stated in the Optional Equipment and Selection Guide;

(f) One year for Customer Requests (CRQs), Interior Components, Interior Furnishings, and Paint;

Any remaining term of this Limited Warranty is automatically transferred to subsequent purchasers of the aircraft.

Cessna's obligation under this Limited Warranty is limited to repairing or replacing, in Cessna's sole discretion, any part or parts which: (1) within the applicable warranty period and 120 days of failure, (2) are returned at the owner's expense to the facility, where the replacement part is procured, whether Citation Parts Distribution or a Cessna-owned Citation service facility or a Citation service facility authorized by Cessna to perform service on the aircraft (collectively "Support Facility"), (3) are accompanied by a completed claim form containing the following information: aircraft model, aircraft serial number, customer number, failed part number and serial number if applicable, failure date, sales order number, purchased part number and serial number if applicable, failure codes, and action codes, and (4) are found by Cessna or its designee to be defective. Replacement parts must be procured through a Support Facility and are only warranted for the remainder of the applicable original aircraft warranty period. A new warranty period is not established for replacement parts. The repair or replacement of defective parts under this Limited Warranty will be made by any Cessna-owned Citation service facility or a Citation service facility authorized by Cessna to perform service on the aircraft without

17. LIMITED WARRANTIES (Continued)

charge for parts and/or labor for removal, installation, and/or repair. All expedited freight transportation expenses, import duties, customs brokerage fees, sales taxes and use taxes, if any, on such warranty repairs or replacement parts are the warranty recipient's sole responsibility. Cessna's performance under this limited warranty may be delayed or prohibited if export licenses are required to be approved by the US Government before specific spare parts can be shipped to Purchaser in some foreign countries. (Location of Cessna-owned and Cessna-authorized Citation service facilities will be furnished by Cessna upon request.)

This Limited Warranty applies to only items detailed herein which have been used, maintained, and operated in accordance with Cessna and other applicable manuals, bulletins, and other written instructions. However, this Limited Warranty does not apply to items that have been subjected to misuse, abuse, negligence, accident, or neglect; to items that have been installed, repaired, or altered by repair facilities not authorized by Cessna; or to items that, in the sole judgment of Cessna, have been installed, repaired, or altered by other than Cessna-owned service facilities contrary to applicable manuals, bulletins, and/or other written instructions provided by Cessna so that the performance, stability, or reliability of such items are adversely affected. Limited Warranty does not apply to normal maintenance services (such as engine adjustments, cleaning, control rigging, brake and other mechanical adjustments, and maintenance inspections); or to the replacement of service items (such as brake linings, lights, filters, de-ice boots, hoses, belts, tires, and rubber-like items); or to normal deterioration of appurtenances (such as paint, cabinetry, and upholstery), corrosion or structural components due to wear, exposure, and neglect.

WITH THE EXCEPTION OF THE WARRANTY OF TITLE AND TO THE EXTENT ALLOWED BY APPLICABLE LAW, THIS LIMITED WARRANTY IS EXPRESSLY IN LIEU OF ANY OTHER WARRANTIES, EXPRESSED OR IMPLIED, IN FACT OR BY LAW, APPLICABLE TO THE AIRCRAFT. CESSNA SPECIFICALLY DISCLAIMS AND EXCLUDES ALL OTHER WARRANTIES, INCLUDING, BUT NOT LIMITED TO, ANY IMPLIED WARRANTY OF MERCHANTABILITY OR FITNESS FOR A PARTICULAR PURPOSE. THE AFOREMENTIONED REMEDIES OF REPAIR OR REPLACEMENT ARE THE ONLY REMEDIES UNDER THIS LIMITED WARRANTY. CESSNA EXPRESSLY AND SPECIFI-

CALLY DISCLAIMS ALL OTHER REMEDIES, OBLIGATIONS, AND LIABILITIES, INCLUDING, BUT NOT LIMITED TO, LOSS OF AIRCRAFT USE, LOSS OF TIME, INCONVENIENCE, COMMERCIAL LOSS, LOSS OF PROFITS, LOSS OF GOODWILL, AND ANY AND ALL OTHER CONSEQUENTIAL AND INCIDENTAL DAMAGES. CESSNA NEITHER ASSUMES NOR AUTHORIZES ANYONE ELSE TO ASSUME ON ITS BEHALF ANY FURTHER OBLIGATIONS OR LIABILITIES PERTAINING TO THE AIRCRAFT NOT CONTAINED IN THIS LIMITED WARRANTY.

17.2 Williams FJ44-3A Limited Engine Warranty

This limited warranty covers Williams International Co., LLC's (Williams) FJ44-3A Engines, Spare Parts and Exchange Parts installed in Cessna aircraft which are sold for Commercial Business Jet use. Capitalized terms used throughout this warranty are defined in Section II hereof.

SECTION I: ALLOWANCES

1. ENGINE WARRANTY

Williams warrants to the Owner or Operator that each new Engine sold for installation on Aircraft (as either original equipment or a Spare Part) will at the time of delivery be free from defects in material, workmanship and title. Warranty shall run to the original purchaser, its successors, assigns, and customers when they are the Owner or Operator. This warranty shall expire 36 months from the date of delivery to the original retail purchaser or First User or 1,500 Engine Operating Hours (EOH) prorated on a straight line basis to 2,000 EOH, whichever occurs first. Williams will, at its option, during the warranty period:

1.1 Undertake Repair or replacement of an Engine, which in the sole discretion of Williams is found to have suffered a Failure pursuant to the definition of "Failure" in Section II, Paragraph 3.4 of this warranty;

1.2 For engines which have 1,500 EOH or less, grant an allowance of 100 percent of the Price of Parts suffering Failure or Resultant Damage (or at its option Repair or exchange such Parts free of charge) plus reasonable cost of labor used during Repair at Williams' authorized Repair Facility;

1.3 For engines which have 1,500 to 2,000 EOH, grant an allowance of, based on a straight line basis, the Price of Parts suffering Failure or Resultant Damage, or at its

July 2008, Revision F

17. LIMITED WARRANTIES (Continued)

option, the Price to Repair or exchange such failed or damaged Parts.

2. SPARE PARTS AND EXCHANGE PARTS WARRANTY

Williams warrants to the Owner or Operator that each new Spare Part or Exchange Part sold for installation in Engines will at the time of delivery be free from defects in material, workmanship and title. Warranty shall run to the original purchaser, its successors, assigns, and customers when they are the Owner or Operator. This warranty shall expire 36 months from the date of shipment from Williams or 12 months from the day of installation of the new Spare Part or Exchange Part in an Engine, whichever occurs first. Williams will during this warranty period grant an allowance of 100 percent on the Price of the Spare Part or Exchange Part which, in the sole discretion of Williams is found to have suffered a Failure or the Resultant Damage of a warranted Part or at its option Repair or exchange such Spare Part or Exchange Part free of charge.

SECTION II: DEFINITIONS

3. In this warranty, the following definitions shall apply to the exclusion of all other meanings, and words in the plural shall have similar meanings:

3.1 "Commercial Use" means the operation of the Engines in aircraft licensed by FAA or its equivalent for general civilian and Commercial Use excluding aerial dusting and spraying and any other type of flying requiring special authorization or dispensation by FAA or its equivalent;

3.2 "Engine" means a Williams' FJ44-3A Engine;

3.3 "Engine Operating Hours" means the total number of hours run by an Engine since new; and

3.4 "Failure" means the breakdown or deterioration of a Part or Spare Part or Exchange Part which is established to the reasonable satisfaction of Williams to be due to a defect in material or workmanship in the manufacture of that Part or Spare Part or Exchange Part and which either:

3.4.1 Necessitates the removal of the Engine or Part or Spare Part or Exchange Part from the aircraft before the next scheduled shop visit of the Engine, or is discovered during a Repair performed in connection with such removal; or

3.4.2 Is discovered during a scheduled shop visit and necessitates the scrapping of the Part or Spare Part or Exchange Part because in the opinion of Williams,

the Part or Spare Part or Exchange Part is beyond Repair in accordance with Repair instructions approved in writing by Williams.

3.5 "First User" means that individual, firm or agency effecting initial operation of the Engine, exclusive of operation incidental to production and initial distribution of the aircraft in which the Engine is installed.

3.6 "Operator" means that individual, firm or agency actually operating the Engine as Part of an Aircraft.

3.7 "Owner" means the Owner of the aircraft in which the Engine is installed who is registered with the Federal Aviation Agency (FAA) or its equivalent at the time of the warranty claim, or the legal Owner of the Engine.

3.8 "Part" means any Part manufactured or supplied by Williams, originally assembled into or attached to an Engine. "Spare Part" means any Part manufactured or supplied by Williams, not originally assembled into or attached to an Engine. "Exchange Part" means any Part or Spare Part which has been newly overhauled in accordance with 14 CFR Part 43. Where two or more Parts are permanently attached together by a manufacturing process, Part or Spare Part or Exchange Part means the minimum assembly listed in the Williams' Illustrated Parts Catalog.

3.9 "Price" as used in 1. Engine Warranty, and 2. Spare Parts and Exchange Parts Warranty, of Section I, Allowances, means the net selling Price to the Operator (excluding import duties and sales or other taxes imposed in the Operator's country), last published by Williams, prior to the time when the Failure is discovered.

3.10 "Repair" means the work comprising the tear down of one or more major assemblies which is required to render serviceable an Engine or Part or Spare Part or Exchange Part which has suffered Failure, necessitating the removal of that Engine from the aircraft.

3.11 "Resultant Damage" means the damage suffered by a Part, necessitating the scrapping of that Part because that Part is beyond economic Repair in accordance with Repair instructions approved in writing by Williams, provided such damage is caused by the Failure of another warranted Part.

SECTION III: GOVERNING CONDITIONS

4. The obligations of Williams hereunder shall be subject to the following conditions:

4.1 The Operator shall present any claim to Williams in

17. LIMITED WARRANTIES (Continued)

writing within 30 days after the date upon which the claim is discovered, shall keep and disclose accurate records of Engine operation and maintenance adequate to support such claims, and shall ship the failed Engine or Part for Repair or replacement within 30 days after notice;

4.2 Williams shall have no obligation under this Warranty in respect of any Engine, Part, Spare Part or Exchange Part which in the reasonable opinion of Williams:

4.2.1 Has not been properly installed, operated, and maintained in accordance with the recommendations of Williams, as contained in its manuals or other written instructions, including operating procedures;

4.2.2 Has been repaired or altered outside the authorized facilities of Williams;

4.2.3 Has been subject to misuse, negligence, accident;

4.2.4 Has suffered damage due to the ingestion of a foreign body; or

4.2.5 Was acquired by the Operator other than from Williams, or through channels not specifically approved in writing by Williams.

4.3 Except as expressly stated in Section I, Allowances, hereof, Williams shall not be liable for any other expenses, taxes, duties or liabilities. In particular costs of removal or replacement from/in an aircraft and transportation costs to/from a Repair facility are excluded from Section I, Allowances.

4.4 The Operator shall notify a Williams' Customer Support representative of a potential warranty problem prior to removing or shipping Engines pursuant to a warranty claim. The Operator shall make available as requested all Engines, Parts, Spare Parts and Exchange Parts for inspection and preliminary analysis relative to

said claim.

4.5 Upon request of Williams, any Part, Spare Part or Exchange Part for which an allowance has been granted by Williams, hereunder, shall be returned by the Operator at Williams' expense, and upon such return any such Part, Spare Part or Exchange Part shall become the property of Williams.

4.6 Duration of the warranty for Products replaced under the terms of this Warranty shall be for the unused portion of the new Engine warranty, Spare Part or Exchange Part warranty as applicable. Replacement of an Engine, Spare Part or Exchange Part does not commence a new warranty period.

4.7 Williams reserves the right to make changes in the design and to add improvements without incurring any obligation to incorporate the same on other Engines or Parts sold by Williams.

4.8 ALL OTHER WARRANTIES, WHETHER EXPRESS, IMPLIED OR STATUTORY, SUCH AS WARRANTIES OF MERCHANTABILITY OR FITNESS FOR A PARTICULAR PURPOSE ARE HEREBY EXCLUDED AND DISCLAIMED TO THE EXTENT THEY EXCEED THE WARRANTIES GRANTED HEREIN. THIS WARRANTY COMPRISES WILLIAMS' ENTIRE LIABILITY IN RELATION TO ANY MALFUNCTION, FAILURE OR DEFECT TO THE EXCLUSION OF ALL OTHER LIABILITY, IN TORT (WHETHER FOR NEGLIGENCE, PRODUCT LIABILITY OR OTHERWISE) OR IN CONTRACT, INCLUDING LIABILITY FOR CONSEQUENTIAL OR INCIDENTAL LOSS, DAMAGE OR EXPENSE.

4.9 NO AGREEMENT EXTENDING THIS WARRANTY SHALL BE BINDING UPON WILLIAMS, UNLESS IN WRITING AND SIGNED BY A DULY AUTHORIZED OFFICER OR REPRESENTATIVE OF WILLIAMS.

18. CITATION CJ3 CREW TRAINING AGREEMENT

Training for one (1) Citation CJ3 crew will be furnished to First Retail Purchaser (hereinafter called the "Purchaser"), subject to the following:

1. A crew shall consist of up to two (2) licensed pilots with current private or commercial, instrument and multi-engine ratings and a minimum of 1,000 hours total airplane pilot time and up to two (2) mechanics with A&P licenses or equivalent experience.

2. Training shall be conducted by Cessna or by its designated training organization.

a. A simulator shall be utilized which is FAA certified to provide training for the CE-525 FAA type rating.

b. In lieu of a model specific simulator, training will be provided in the most appropriate type simulator available capable of accomplishing the FAA type rating, with differences training provided.

c. Additional training as requested by the customer, shall be conducted in the customer's aircraft.

d. Location of training to be Wichita, Kansas or

July 2008, Revision F

18. CITATION CJ3 CREW TRAINING AGREEMENT (Continued)

unless mutually agreed otherwise. The organization conducting the training is hereinafter called the "Trainer."

3. Training furnished shall consist of the following:
 - a. Flight training to flight proficiency in accordance with Trainer's standards aimed toward type certification of two (2) Captains under applicable Federal Air Regulations not to exceed five (5) total hours for the two (2) pilots.
 - b. Flight simulation training to simulator proficiency in accordance with Trainer's standards but not to exceed thirty (30) total hours for both pilots.
 - c. Ground School training for each pilot and classroom instruction for each mechanic in accordance with Trainer's standards.
4. Purchaser shall be responsible for:
 - a. Transportation of crew to and from training site and for living expenses during training.
 - b. Providing an interpreter during the course of training for any of Purchaser's crew not conversant with the English language.
 - c. Payment to Trainer for additional simulator or flight training beyond that required to attain proficiency in accordance with Trainer's standards for the course in which the pilot is enrolled.
 - d. All aircraft required for flight training as well as all landing fees, fuel costs, aircraft maintenance and insurance and all other direct costs of operation, including applicable taxes required in connection with the operation of said aircraft during such flight training.
 - e. Extra charges, if any, for scheduling pilots in separate training classes.
 - f. Reimbursing to Cessna the retail rate for training in the event of training before actual sale/delivery, if sale/delivery is cancelled.
5. Seller or Trainer shall schedule all training, furnish Purchaser schedules of training and endeavor to schedule training at a convenient time for Purchaser. A cancellation fee of Two Hundred Dollars (\$200) will be paid by Purchaser if crew fails to appear for scheduled training, except for reasons beyond its reasonable control, unless Purchaser gives Seller written notice of cancellation received at Wichita, Kansas, at least seven (7) days prior to scheduled training. In the event of such cancellation Seller shall reschedule training for the next available class.
6. Neither Seller nor Trainer shall be responsible for the

competency of Purchaser's crew during and after training. Trainer will make the same efforts to qualify Purchaser's crew as it makes in training of other Citation CJ3 crews; however, Seller and Trainer cannot guarantee Purchaser's crew shall qualify for any license, certificate or rating.

7. Neither Seller nor Trainer shall be responsible for any delay in providing training due to causes beyond its or their reasonable control.

8. All Training furnished to Purchaser under the Agreement will be scheduled to commence no earlier than three (3) months prior to delivery and will be completed within twelve (12) months after delivery of the Aircraft unless mutually agreed otherwise.

Signature of the Purchaser to the Purchase Agreement to which this Training Agreement is attached as a part of the Specification and Description shall constitute acceptance by Purchaser of the foregoing terms and conditions relative to training to be furnished by Seller. Purchaser agrees that Seller can provide Purchaser's name and address to the training organization for the purpose of coordinating training.

